



23010 N. 19th Ave
 Bldg 2 - Ste 48
 Phoenix, AZ 85065
 1-800-243-0820

Custom Product Design Information Angio II

Company

Contact Name

Phone/Email

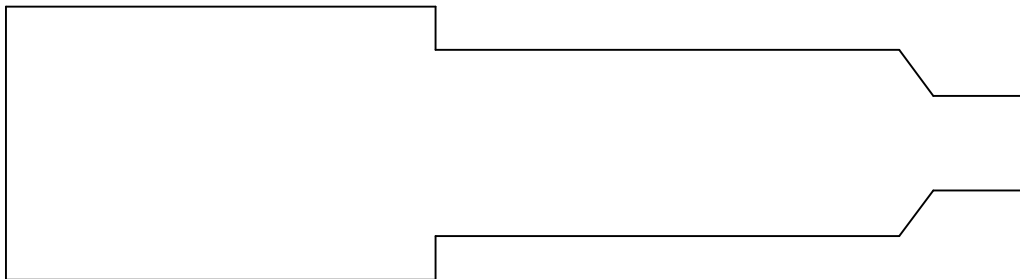
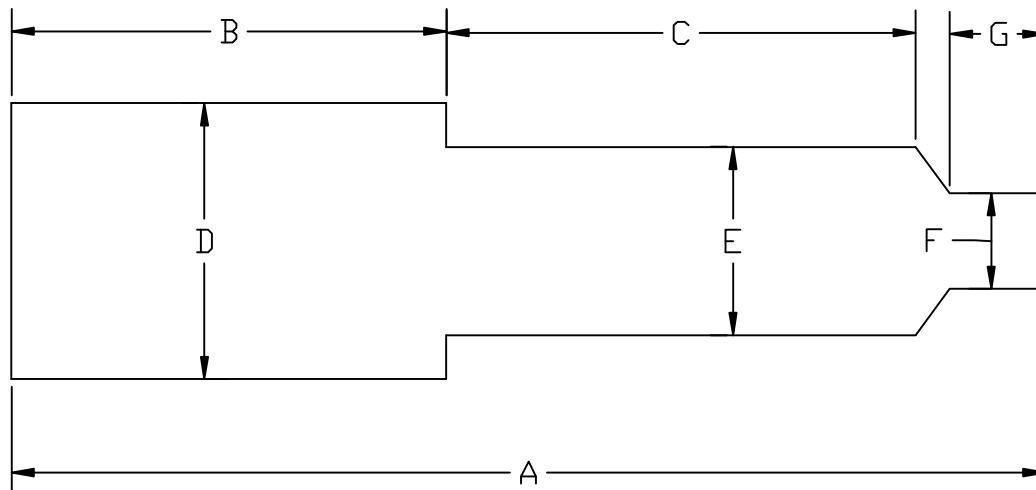

Please measure your pad/cushion at each lettered position shown in the illustration. Write the measures in the Table of Measures provided below

Table of Measures	
Letter	Measure (Inch or cm)
A	
B	
C	
D	
E	
F	
G	
Thickness	

If your pad/cushion fastens to the table using Hook and Loop fastener (i.e. Velcro®), or other methods, please use the illustration to the left to sketch the locations and the measures of their position.

Please return this completed form to RadScan Medical Equipment, Inc. at:
 Fax: 623-580-0115
 Email: orders@radscanmedical.com